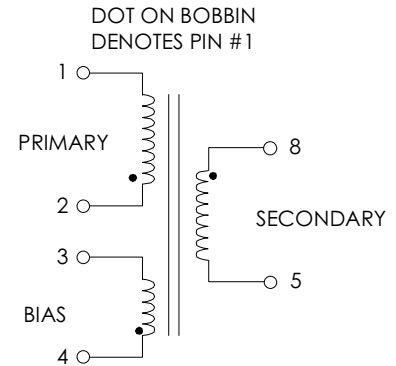

**TABLE 1: ELECTRICAL SPECIFICATIONS AT 25 °C**  
 SWITCHING TRANSFORMER DESIGNED FOR USE WITH POWER INTEGRATIONS  
 PWR-TOP210PFI REFER TO APPLICATION CIRCUIT OF FIGURE 3

PARAMETER	SPEC LIMITS			UNITS
	MIN.	TYP.	MAX.	
PRIMARY INDUCTANCE (2-1) VOLTAGE = 0.250Vrms FREQUENCY = 100 KHZ	7.10	8.10	9.10	mHY
TURNRATIO'S: SECONDARY (8-5) : PRIMARY (2-1) BIAS (4-3) : PRIMARY (2-1)	—	1:17.00 1: 8.50	—	± 3%
PRI LEAKAGE IND. (8-5 SHORTED) VOLTAGE = 0.250Vrms FREQUENCY = 100 KHZ	—	125.0	140.0	μHY
HIPOT: PRIMARY TO SECONDARY BIAS TO SECONDARY	3000 3000	— —	— —	Vrms Vrms
APP CIRCUIT PARAMETERS: (1) AC LINE VOLTAGE 47/400 Hz OUTPUT VOLTAGE OUTPUT CURRENT CONTINUOUS OUTPUT CURRENT PEAK LINE REGULATION (85 TO 265Vac) LOAD REGULATION 10-100% RIPPLE	85 — 0.0 — — — — —	— 5.0 — — 0.20 0.20 50.0	265 — 600 800 — — —	Vac Vdc mA mA ±% ±% ±mV

**FIGURE 1: SCHEMATIC DIAGRAM**



**NOTE1:**  
**REINFORCED INSULATION SYSTEM, UL1950, IEC950, CSA-950:**  
 A) ALL MATERIALS MEET "UL", "CSA" & "IEC" REQUIREMENTS  
 B) TRIPLE BASIC INSULATED SECONDARY.  
 C) DESIGNED TO MEET ≥5.0mm CREEPAGE REQUIREMENTS.  
 D) VARNISH FINISHED ASSEMBLY.  
 E) UL 1950 & CSA-950 CERTIFIED: FILE #E162344.  
 F) UL CLASS (B) 130 INSULATION SYSTEM PM130-R1, PM130-H1, PM130-H1A (UL FILE #E177139) OR ANY UL AUTHORIZED CLASS (B) INSULATION SYSTEM.

(1) REFER TO APPLICATION CIRCUIT OF FIGURE 3.

**FIGURE 2: PHYSICAL DIMENSIONS mm (INCHES)**

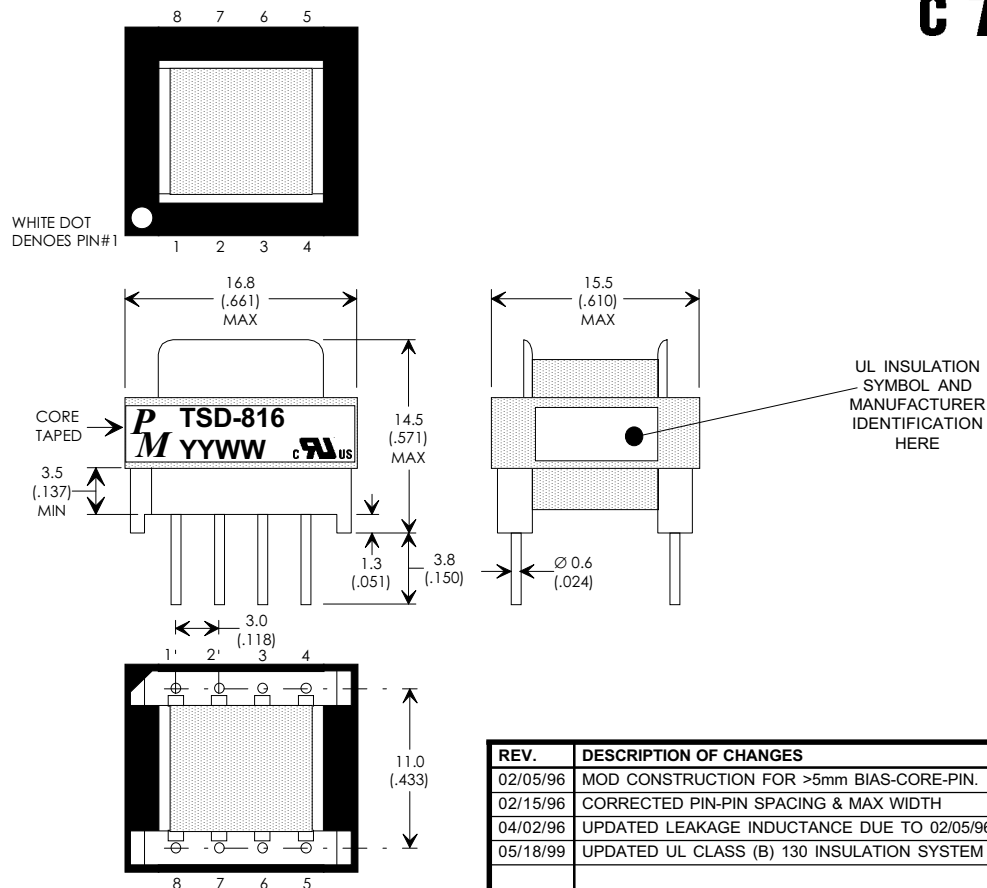

EE16/EI16, 8-PIN HORIZONTAL

REV.	DESCRIPTION OF CHANGES	BY
02/05/96	MOD CONSTRUCTION FOR >5mm BIAS-CORE-PIN.	TO
02/15/96	CORRECTED PIN-PIN SPACING & MAX WIDTH	TO
04/02/96	UPDATED LEAKAGE INDUCTANCE DUE TO 02/05/96 REV ABOVE.	TO
05/18/99	UPDATED UL CLASS (B) 130 INSULATION SYSTEM	MD



**Premier  
Magnetics Inc.**

UNLESS OTHERWISE SPECIFIED  
 DIMENSIONS ARE IN MM  
 DIMENSIONAL TOLERANCES ARE:  
 DECIMALS ANGLES  
 .X ± .25 ±0° 30'  
 .XX ± .15  
 DO NOT SCALE DRAWING

**TRANSFORMER CONTROL DRAWING**

PREMIER P/N: TSD-816	REVISION: 05/18/99
DRAWN BY: TOM O'NEIL	REF: PWR-TOP210PFI
SCALE: NONE	SHEET: 1 OF 6

## APPLICATION NOTES

Premier Magnetics' TSD-816 Switch Mode Transformer was designed for use with Power Integrations, Inc. PWR-TOP210PFI three terminal off-line PWM switching regulator in the Flyback Buck-Boost circuit configuration. This conversion topology can provide isolated multiple outputs with efficiencies up to 90%. Premier's TSD-816 transformer has been optimized to provide maximum power throughput.

The PWR-TOPXXX series from Power Integrations, Inc. are self contained 100KHz three terminal voltage controlled PWM switching regulators. This series contains all necessary functions for an off-line switched mode control DC power source. These switching regulators provide a very simple solution to off-line designs. The inductors and transformer used with the PWR-TOPXXX are critical to the performance of the circuit. They define the overall efficiency, output power and overall physical size.

Below is a universal input high precision 3W watt application circuit utilizing Power Integrations PWR-TOP210PFI switching regulator in the flyback buck-boost configuration. The component values listed are intended for reference purposes only. The EMI/RFI capacitors C7 & C8 are shown for reference but may not be needed to meet EMI/RFI emission specifications.

**FIGURE 3: TYPICAL APPLICATION CIRCUIT**

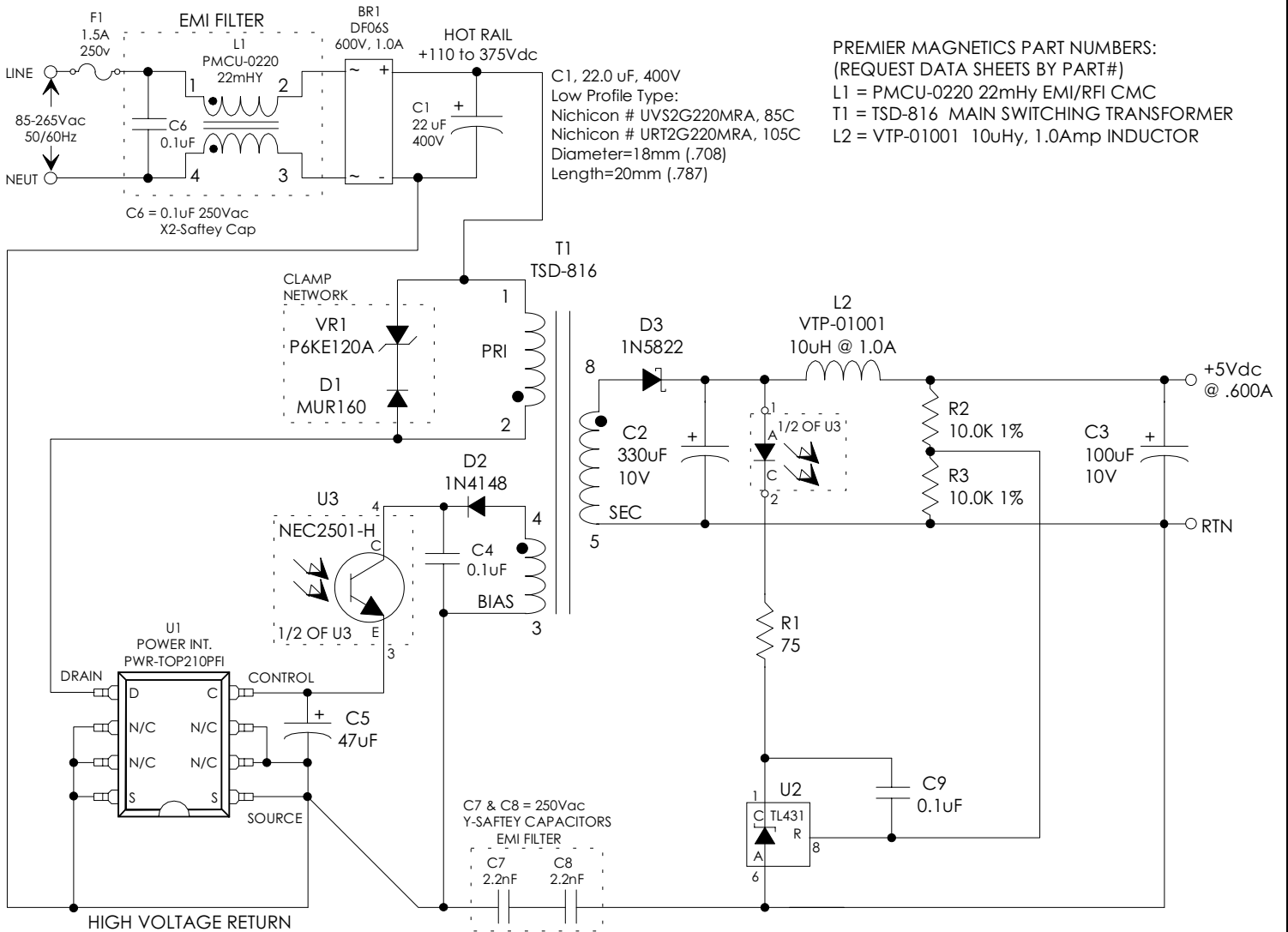

**Premier  
Magnetics Inc.**

UNLESS OTHERWISE SPECIFIED  
DIMENSIONS ARE IN MM  
DIMENSIONAL TOLERANCES ARE:  
DECIMALS ANGLES  
.X ± .25 ±0° 30'  
.XX ± .15  
DO NOT SCALE DRAWING

### TRANSFORMER CONTROL DRAWING

PREMIER P/N: TSD-816	REVISION: 05/18/99
DRAWN BY: TOM O'NEIL	REF: PWR-TOP210PFI
SCALE: NONE	SHEET: 2 OF 6